

Isometric Immersions and Compensated Compactness

Gui-Qiang Chen¹, Marshall Slemrod², Dehua Wang³

¹ Department of Mathematics, Northwestern University, Evanston, IL 60208, USA.

E-mail: gqchen@math.northwestern.edu

² Department of Mathematics, University of Wisconsin, Madison, WI 53706, USA.

E-mail: slemrod@math.wisc.edu

³ Department of Mathematics, University of Pittsburgh, Pittsburgh, PA 15260, USA.

E-mail: dwang@math.pitt.edu

Received: 27 December 2008 / Accepted: 10 September 2009

Published online: 27 November 2009 – © Springer-Verlag 2009

Abstract: A fundamental problem in differential geometry is to characterize intrinsic metrics on a two-dimensional Riemannian manifold \mathcal{M}^2 which can be realized as isometric immersions into \mathbb{R}^3 . This problem can be formulated as initial and/or boundary value problems for a system of nonlinear partial differential equations of mixed elliptic-hyperbolic type whose mathematical theory is largely incomplete. In this paper, we develop a general approach, which combines a fluid dynamic formulation of balance laws for the Gauss-Codazzi system with a compensated compactness framework, to deal with the initial and/or boundary value problems for isometric immersions in \mathbb{R}^3 . The compensated compactness framework formed here is a natural formulation to ensure the weak continuity of the Gauss-Codazzi system for approximate solutions, which yields the isometric realization of two-dimensional surfaces in \mathbb{R}^3 .

As a first application of this approach, we study the isometric immersion problem for two-dimensional Riemannian manifolds with strictly negative Gauss curvature. We prove that there exists a $C^{1,1}$ isometric immersion of the two-dimensional manifold in \mathbb{R}^3 satisfying our prescribed initial conditions. To achieve this, we introduce a vanishing viscosity method depending on the features of initial value problems for isometric immersions and present a technique to make the a priori estimates including the L^∞ control and H^{-1} -compactness for the viscous approximate solutions. This yields the weak convergence of the vanishing viscosity approximate solutions and the weak continuity of the Gauss-Codazzi system for the approximate solutions, hence the existence of an isometric immersion of the manifold into \mathbb{R}^3 satisfying our initial conditions. The theory is applied to a specific example of the metric associated with the catenoid.

1. Introduction

A fundamental problem in differential geometry is to characterize intrinsic metrics on a two-dimensional Riemannian manifold \mathcal{M}^2 which can be realized as isometric immersions into \mathbb{R}^3 (cf. Yau [40]; also see [21, 34, 36]). Important results have been achieved

for the embedding of surfaces with positive Gauss curvature which can be formulated as an elliptic boundary value problem (cf. [21]). For the case of surfaces of negative Gauss curvature where the underlying partial differential equations are hyperbolic, the complimentary problem would be an initial or initial-boundary value problem. Hong in [23] first proved that complete negatively curved surfaces can be isometrically immersed in \mathbb{R}^3 if the Gauss curvature decays at a certain rate in the time-like direction. In fact, a crucial lemma in Hong [23] (also see Lemma 10.2.9 in [21]) shows that, for such a decay rate of the negative Gauss curvature, there exists a unique global smooth, small solution forward in time for prescribed smooth, small initial data. Our main theorem, Theorem 5.1(i), indicates that in fact we can solve the corresponding problem for a class of *large* non-smooth initial data. Possible implication of our approach may be in existence theorems for equilibrium configurations of a catenoidal shell as detailed in Vaziri-Mahedevan [39]. When the Gauss curvature changes sign, the immersion problem then becomes an initial-boundary value problem of mixed elliptic-hyperbolic type, which is still under investigation.

The purpose of this paper is to introduce a general approach, which combines a fluid dynamic formulation of balance laws with a compensated compactness framework, to deal with the isometric immersion problem in \mathbb{R}^3 (even when the Gauss curvature changes sign). In Sect. 2, we formulate the isometric immersion problem for two-dimensional Riemannian manifolds in \mathbb{R}^3 via solvability of the Gauss-Codazzi system. In Sect. 3, we introduce a fluid dynamic formulation of balance laws for the Gauss-Codazzi system for isometric immersions. Then, in Sect. 4, we provide a compensated compactness framework and present one of our main observations that this framework is a natural formulation to ensure the weak continuity of the Gauss-Codazzi system for approximate solutions, which yields the isometric realization of two-dimensional surfaces in \mathbb{R}^3 . A generalization of this approach to higher dimensional immersions has been given in Chen-Slemrod-Wang [8].

In Sect. 5, as a first application of this approach, we focus on the isometric immersion problem of two-dimensional Riemannian manifolds with strictly negative Gauss curvature. Since the local existence of smooth solutions follows from the standard hyperbolic theory, we are concerned here with the global existence of solutions of the initial value problem with large initial data. The metrics g_{ij} we study have special structures and forms usually associated with the catenoid of revolution when $g_{11} = g_{22} = \cosh(x)$ and $g_{12} = 0$. For these cases, while Hong's theorem [23] applies to obtain the existence of a solution for small smooth initial data, our result yields a large-data existence theorem for a $C^{1,1}$ isometric immersion.

To achieve this, we introduce a vanishing viscosity method depending on the features of the initial value problem for isometric immersions and present a technique to make the a priori estimates including the L^∞ control and H^{-1} -compactness for the viscous approximate solutions. This yields the weak convergence of the vanishing viscosity approximate solutions and the weak continuity of the Gauss-Codazzi system for the approximate solutions, hence the existence of a $C^{1,1}$ -isometric immersion of the manifold into \mathbb{R}^3 with prescribed initial conditions.

We remark in passing that, for the fundamental ideas and early applications of compensated compactness, see the classical papers by Tartar [38] and Murat [32]. For applications to the theory of hyperbolic conservation laws, see for example [4, 10, 13, 18, 37]. In particular, the compensated compactness approach has been applied in [3, 6, 11, 12, 25, 26] to the one-dimensional Euler equations for unsteady isentropic flow, allowing for cavitation, in Morawetz [29, 30] and Chen-Slemrod-Wang [7] for two-dimensional

steady transonic flow away from stagnation points, and in Chen-Dafermos-Slemrod-Wang [5] for subsonic-sonic flows.

2. The Isometric Immersion Problem for Two-Dimensional Riemannian Manifolds in \mathbb{R}^3

In this section, we formulate the isometric immersion problem for two-dimensional Riemannian manifolds in \mathbb{R}^3 via solvability of the Gauss-Codazzi system.

Let $\Omega \subset \mathbb{R}^2$ be an open set. Consider a map $\mathbf{r} : \Omega \rightarrow \mathbb{R}^3$ so that, for $(x, y) \in \Omega$, the two vectors $\{\partial_x \mathbf{r}, \partial_y \mathbf{r}\}$ in \mathbb{R}^3 span the tangent plane at $\mathbf{r}(x, y)$ of the surface $\mathbf{r}(\Omega) \subset \mathbb{R}^3$. Then

$$\mathbf{n} = \frac{\partial_x \mathbf{r} \times \partial_y \mathbf{r}}{|\partial_x \mathbf{r} \times \partial_y \mathbf{r}|}$$

is the unit normal of the surface $\mathbf{r}(\Omega) \subset \mathbb{R}^3$. The metric on the surface in \mathbb{R}^3 is

$$ds^2 = d\mathbf{r} \cdot d\mathbf{r} \tag{2.1}$$

or, in local (x, y) -coordinates,

$$ds^2 = (\partial_x \mathbf{r} \cdot \partial_x \mathbf{r}) (dx)^2 + 2(\partial_x \mathbf{r} \cdot \partial_y \mathbf{r}) dx dy + (\partial_y \mathbf{r} \cdot \partial_y \mathbf{r}) (dy)^2. \tag{2.2}$$

Let $g_{ij}, i, j = 1, 2$, be the given metric of a two-dimensional Riemannian manifold \mathcal{M} parameterized on Ω . The first fundamental form I for \mathcal{M} on Ω is

$$I := g_{11}(dx)^2 + 2g_{12}dx dy + g_{22}(dy)^2. \tag{2.3}$$

Then the isometric immersion problem is to seek a map $\mathbf{r} : \Omega \rightarrow \mathbb{R}^3$ such that

$$d\mathbf{r} \cdot d\mathbf{r} = I,$$

that is,

$$\partial_x \mathbf{r} \cdot \partial_x \mathbf{r} = g_{11}, \quad \partial_x \mathbf{r} \cdot \partial_y \mathbf{r} = g_{12}, \quad \partial_y \mathbf{r} \cdot \partial_y \mathbf{r} = g_{22}, \tag{2.4}$$

so that $\{\partial_x \mathbf{r}, \partial_y \mathbf{r}\}$ in \mathbb{R}^3 are linearly independent.

The equations in (2.4) are three nonlinear partial differential equations for the three components of $\mathbf{r}(x, y)$.

The corresponding second fundamental form is

$$II := -d\mathbf{n} \cdot d\mathbf{r} = h_{11}(dx)^2 + 2h_{12}dx dy + h_{22}(dy)^2, \tag{2.5}$$

and $(h_{ij})_{1 \leq i, j \leq 2}$ is the orthogonality of \mathbf{n} to the tangent plane. Since $\mathbf{n} \cdot d\mathbf{r} = 0$, then $d(\mathbf{n} \cdot d\mathbf{r}) = 0$ implies

$$-II + \mathbf{n} \cdot d^2 \mathbf{r} = 0, \quad \text{i.e.,} \quad II = (\mathbf{n} \cdot \partial_x^2 \mathbf{r}) (dx)^2 + 2(\mathbf{n} \cdot \partial_{xy}^2 \mathbf{r}) dx dy + (\mathbf{n} \cdot \partial_y^2 \mathbf{r}) (dy)^2.$$

The fundamental theorem of surface theory (cf. [14,21]) indicates that there exists a surface in \mathbb{R}^3 whose first and second fundamental forms are I and II if the smooth coefficients (g_{ij}) and (h_{ij}) of the two given quadratic forms I and II with $(g_{ij}) > 0$ satisfy the Gauss-Codazzi system. It is indicated in Mardare [28] (Theorem 9; also see [27]) that this theorem holds even when (h_{ij}) is only in L^∞ for given (g_{ij}) in $C^{1,1}$, for

which the immersion surface is $C^{1,1}$. This shows that, for the realization of a two-dimensional Riemannian manifold in \mathbb{R}^3 with given metric $(g_{ij}) > 0$, it suffices to solve for $(h_{ij}) \in L^\infty$ determined by the Gauss-Codazzi system to recover \mathbf{r} a posteriori.

The simplest way to write the Gauss-Codazzi system (cf. [14,21]) is as

$$\begin{aligned} \partial_x M - \partial_y L &= \Gamma_{22}^{(2)} L - 2\Gamma_{12}^{(2)} M + \Gamma_{11}^{(2)} N, \\ \partial_x N - \partial_y M &= -\Gamma_{22}^{(1)} L + 2\Gamma_{12}^{(1)} M - \Gamma_{11}^{(1)} N, \end{aligned} \tag{2.6}$$

with

$$LN - M^2 = \kappa. \tag{2.7}$$

Here

$$L = \frac{h_{11}}{\sqrt{|g|}}, \quad M = \frac{h_{12}}{\sqrt{|g|}}, \quad N = \frac{h_{22}}{\sqrt{|g|}},$$

$|g| = \det(g_{ij}) = g_{11}g_{22} - g_{12}^2$, $\kappa(x, y)$ is the Gauss curvature that is determined by the relation:

$$\kappa(x, y) = \frac{R_{1212}}{|g|}, \quad R_{ijkl} = g_{lm} \left(\partial_k \Gamma_{ij}^{(m)} - \partial_j \Gamma_{ik}^{(m)} + \Gamma_{ij}^{(n)} \Gamma_{nk}^{(m)} - \Gamma_{ik}^{(n)} \Gamma_{nj}^{(m)} \right),$$

R_{ijkl} is the curvature tensor and depends on (g_{ij}) and its first and second derivatives, and

$$\Gamma_{ij}^{(k)} = \frac{1}{2} g^{kl} (\partial_j g_{il} + \partial_i g_{jl} - \partial_l g_{ij})$$

is the Christoffel symbol and depends on the first derivatives of (g_{ij}) , where the summation convention is used, (g^{kl}) denotes the inverse of (g_{ij}) , and $(\partial_1, \partial_2) = (\partial_x, \partial_y)$.

Therefore, given a positive definite metric $(g_{ij}) \in C^{1,1}$, the Gauss-Codazzi system gives us three equations for the three unknowns (L, M, N) determining the second fundamental form II . Note that, although (g_{ij}) is positive definite, R_{1212} may change sign and so does the Gauss curvature κ . Thus, as we will discuss in Sect. 3, the Gauss-Codazzi system (2.6)–(2.7) generically is of mixed hyperbolic-elliptic type, as in transonic flow (cf. [2,7,9,31]). In §3–4, we introduce a general approach to deal with the isometric immersion problem involving nonlinear partial differential equations of mixed hyperbolic-elliptic type by combining a fluid dynamic formulation of balance laws in §3 with a compensated compactness framework in §4. As an example of direct applications of this approach, in §5 we show how this approach can be applied to establish an isometric immersion of a two-dimensional Riemannian manifold with negative Gauss curvature in \mathbb{R}^3 .

3. Fluid Dynamic Formulation for the Gauss-Codazzi System

From the viewpoint of geometry, the constraint condition (2.7) is a Monge-Ampère equation and the equations in (2.6) are integrability relations. However, our goal here is to put the problem into a fluid dynamic formulation so that the isometric immersion problem may be solved via the approaches that have shown to be useful in fluid dynamics

for solving nonlinear systems of balance laws. To achieve this, we formulate the isometric immersion problem via solvability of the Gauss-Codazzi system (2.6)–(2.7), that is, solving *first* for h_{ij} , $i, j = 1, 2$, via (2.6) with constraint (2.7) and *then* recovering \mathbf{r} a posteriori.

To do this, we set

$$L = \rho v^2 + p, \quad M = -\rho uv, \quad N = \rho u^2 + p,$$

and set $q^2 = u^2 + v^2$ as usual. Then the Codazzi equations in (2.6) become the familiar balance laws of momentum:

$$\begin{aligned} \partial_x(\rho uv) + \partial_y(\rho v^2 + p) &= -(\rho v^2 + p)\Gamma_{22}^{(2)} - 2\rho uv\Gamma_{12}^{(2)} - (\rho u^2 + p)\Gamma_{11}^{(2)}, \\ \partial_x(\rho u^2 + p) + \partial_y(\rho uv) &= -(\rho v^2 + p)\Gamma_{22}^{(1)} - 2\rho uv\Gamma_{12}^{(1)} - (\rho u^2 + p)\Gamma_{11}^{(1)}, \end{aligned} \tag{3.1}$$

and the Gauss equation (2.7) becomes

$$\rho pq^2 + p^2 = \kappa. \tag{3.2}$$

From this, we can see that, if the Gauss curvature κ is allowed to be both positive and negative, the “pressure” p cannot be restricted to be positive. Our simple choice for p is the Chaplygin-type gas:

$$p = -\frac{1}{\rho}.$$

Then, from (3.2), we find

$$-q^2 + \frac{1}{\rho^2} = \kappa,$$

and hence we have the “Bernoulli” relation:

$$\rho = \frac{1}{\sqrt{q^2 + \kappa}}. \tag{3.3}$$

This yields

$$p = -\sqrt{q^2 + \kappa}, \tag{3.4}$$

and the formulas for u^2 and v^2 :

$$u^2 = p(p - M), \quad v^2 = p(p - L), \quad M^2 = (N - p)(L - p).$$

The last relation for M^2 gives the relation for p in terms of (L, M, N) , and then the first two give the relations for (u, v) in terms of (L, M, N) .

We rewrite (3.1) as

$$\begin{aligned} \partial_x(\rho uv) + \partial_y(\rho v^2 + p) &= R_1, \\ \partial_x(\rho u^2 + p) + \partial_y(\rho uv) &= R_2, \end{aligned} \tag{3.5}$$

where R_1 and R_2 denote the right-hand sides of (3.1).

We now find the corresponding “geometric rotationality–continuity equations”. Multiplying the first equation of (3.5) by v and the second by u , and setting

$$\partial_x v - \partial_y u = -\sigma,$$

we see

$$\begin{aligned} \frac{v}{\rho} \operatorname{div}(\rho u, \rho v) - \frac{1}{2} \partial_y \kappa &= \frac{R_1}{\rho} + \sigma u, \\ \frac{u}{\rho} \operatorname{div}(\rho u, \rho v) - \frac{1}{2} \partial_x \kappa &= \frac{R_2}{\rho} - \sigma v, \end{aligned}$$

and hence

$$\begin{aligned} \operatorname{div}(\rho u, \rho v) &= \frac{1}{2} \frac{\rho}{v} \partial_y \kappa + \frac{R_1}{v} + \frac{\rho u \sigma}{v}, \\ \operatorname{div}(\rho u, \rho v) &= \frac{1}{2} \frac{\rho}{u} \partial_x \kappa + \frac{R_2}{u} - \frac{\rho v \sigma}{u}. \end{aligned} \tag{3.6}$$

Thus, the right hand sides of (3.6) are equal, which gives a formula for σ :

$$\sigma = \frac{1}{\rho q^2} \left(v \left(\frac{1}{2} \rho \partial_x \kappa + R_2 \right) - u \left(\frac{1}{2} \rho \partial_y \kappa + R_1 \right) \right). \tag{3.7}$$

If we substitute this formula for σ into (3.6), we can write down our “rotationality–continuity equations” as

$$\partial_x v - \partial_y u = \frac{1}{\rho q^2} \left(u \left(\frac{1}{2} \rho \partial_y \kappa + R_1 \right) - v \left(\frac{1}{2} \rho \partial_x \kappa + R_2 \right) \right), \tag{3.8}$$

$$\partial_x(\rho u) + \partial_y(\rho v) = \frac{1}{2} \frac{\rho u}{q^2} \partial_x \kappa + \frac{1}{2} \frac{\rho v}{q^2} \partial_y \kappa + \frac{v}{q^2} R_1 + \frac{u}{q^2} R_2. \tag{3.9}$$

In summary, the Gauss-Codazzi system (2.6)–(2.7), the momentum equations (3.1)–(3.4), and the rotationality–continuity equations (3.3) and (3.8)–(3.9) are all formally equivalent.

However, for weak solutions, we know from our experience with gas dynamics that this equivalence breaks down. In Chen-Dafermos-Slemrod-Wang [5], the decision was made (as is standard in gas dynamics) to solve the rotationality–continuity equations and view the momentum equations as “entropy” equalities which may become inequalities for weak solutions. In geometry, this situation is just the reverse. It is the Gauss-Codazzi system that must be solved exactly and hence the rotationality–continuity equations will become “entropy” inequalities for weak solutions.

The above issue becomes apparent when we set up “viscous” regularization that preserves the “divergence” form of the equations, which will be introduced in §5.3. This is crucial since we need to solve (3.8)–(3.9) exactly, as we have noted.

To continue further our analogy, let us define the “sound” speed:

$$c^2 = p'(\rho), \tag{3.10}$$

which in our case gives

$$c^2 = \frac{1}{\rho^2}. \tag{3.11}$$

Since our ‘‘Bernoulli’’ relation is (3.3), we see

$$c^2 = q^2 + \kappa. \tag{3.12}$$

Hence, under this formulation,

- (i) when $\kappa > 0$, the ‘‘flow’’ is subsonic, i.e., $q < c$, and system (3.1)–(3.2) is elliptic;
- (ii) when $\kappa < 0$, the ‘‘flow’’ is supersonic, i.e., $q > c$, and system (3.1)–(3.2) is hyperbolic;
- (iii) when $\kappa = 0$, the ‘‘flow’’ is sonic, i.e., $q = c$, and system (3.1)–(3.2) is degenerate.

In general, system (3.1)–(3.2) is of mixed hyperbolic-elliptic type. Thus, the isometric immersion problem involves the existence of solutions to nonlinear partial differential equations of mixed hyperbolic-elliptic type.

4. Compensated Compactness Framework for Isometric Immersions

In this section, we provide a compensated compactness framework and present our new observation that this framework is a natural formulation to ensure the weak continuity of the Gauss-Codazzi system for approximate solutions.

Let a sequence of functions $(L^\varepsilon, M^\varepsilon, N^\varepsilon)(x, y)$, defined on an open subset $\Omega \subset \mathbb{R}^2$, satisfy the following Framework (A):

- (A.1) $|(L^\varepsilon, M^\varepsilon, N^\varepsilon)(x, y)| \leq C$ a.e. $(x, y) \in \Omega$, for some $C > 0$ independent of ε ;
- (A.2) $\partial_x M^\varepsilon - \partial_y L^\varepsilon$ and $\partial_x N^\varepsilon - \partial_y M^\varepsilon$ are confined in a compact set in $H_{loc}^{-1}(\Omega)$;
- (A.3) There exist $o_j^\varepsilon(1)$, $j = 1, 2, 3$, with $o_j^\varepsilon(1) \rightarrow 0$ in the sense of distributions as $\varepsilon \rightarrow 0$ such that

$$\begin{aligned} \partial_x M^\varepsilon - \partial_y L^\varepsilon &= \Gamma_{22}^{(2)} L^\varepsilon - 2\Gamma_{12}^{(2)} M^\varepsilon + \Gamma_{11}^{(2)} N^\varepsilon + o_1^\varepsilon(1), \\ \partial_x N^\varepsilon - \partial_y M^\varepsilon &= -\Gamma_{22}^{(1)} L^\varepsilon + 2\Gamma_{12}^{(1)} M^\varepsilon - \Gamma_{11}^{(1)} N^\varepsilon + o_2^\varepsilon(1), \end{aligned} \tag{4.1}$$

and

$$L^\varepsilon N^\varepsilon - (M^\varepsilon)^2 = \kappa + o_3^\varepsilon(1). \tag{4.2}$$

Then we have

Theorem 4.1. (Compensated compactness framework). *Let a sequence of functions $(L^\varepsilon, M^\varepsilon, N^\varepsilon)(x, y)$ satisfy Framework (A). Then there exists a subsequence (still labeled) $(L^\varepsilon, M^\varepsilon, N^\varepsilon)(x, y)$ that converges weak-star in $L^\infty(\Omega)$ to $(\bar{L}, \bar{M}, \bar{N})$ as $\varepsilon \rightarrow 0$ such that*

- (i) $|(\bar{L}, \bar{M}, \bar{N})(x, y)| \leq C$ a.e. $(x, y) \in \Omega$;
- (ii) the Gauss equation (2.7) is weakly continuous with respect to the subsequence $(L^\varepsilon, M^\varepsilon, N^\varepsilon)(x, y)$ that converges weak-star in $L^\infty(\Omega)$ to $(\bar{L}, \bar{M}, \bar{N})$ as $\varepsilon \rightarrow 0$;
- (iii) the Codazzi equations in (2.6) hold.

Specifically the limit $(\bar{L}, \bar{M}, \bar{N})$ is a bounded weak solution to the Gauss-Codazzi system (2.6)–(2.7), which yields an isometric realization of the corresponding two-dimensional Riemannian manifold in \mathbb{R}^3 .

Proof. By the div-curl lemma of Tartar-Murat [38,32] and the Young measure representation theorem for a uniformly bounded sequence of functions (cf. Tartar [38]), we employ (A.1)–(A.2) to conclude that there exist a family of Young measures $\{\nu_{x,y}\}_{(x,y)\in\Omega}$ and a subsequence (still labeled) $(L^\varepsilon, M^\varepsilon, N^\varepsilon)(x, y)$ that converges weak-star in $L^\infty(\Omega)$ to $(\bar{L}, \bar{M}, \bar{N})$ as $\varepsilon \rightarrow 0$ such that

- (a) $(\bar{L}, \bar{M}, \bar{N})(x, y) = (\langle \nu_{x,y}, L \rangle, \langle \nu_{x,y}, M \rangle, \langle \nu_{x,y}, N \rangle)$ a.e. $(x, y) \in \Omega$;
- (b) $|(\bar{L}, \bar{M}, \bar{N})(x, y)| \leq C$ a.e. $(x, y) \in \Omega$;
- (c) the following commutation identity holds:

$$\langle \nu_{x,y}, M^2 - LN \rangle = \langle \nu_{x,y}, M \rangle^2 - \langle \nu_{x,y}, L \rangle \langle \nu_{x,y}, N \rangle = (\bar{M})^2 - \bar{L}\bar{N}. \tag{4.3}$$

Since the equations in (4.1) are linear in $(L^\varepsilon, M^\varepsilon, N^\varepsilon)$, then the limit $(\bar{L}, \bar{M}, \bar{N})$ also satisfies the equations in (2.6) in the sense of distributions.

Furthermore, condition (4.2) yields that

$$\langle \nu_{x,y}, LN - M^2 \rangle = \kappa(x, y) \quad \text{a.e. } (x, y) \in \Omega. \tag{4.4}$$

The combination (4.3) with (4.4) yields the weak continuity of the Gauss equation with respect to the sequence $(L^\varepsilon, M^\varepsilon, N^\varepsilon)$ that converges weak-star in $L^\infty(\Omega)$ to $(\bar{L}, \bar{M}, \bar{N})$ as $\varepsilon \rightarrow 0$:

$$\bar{L}\bar{N} - (\bar{M})^2 = \kappa.$$

Therefore, $(\bar{L}, \bar{M}, \bar{N})$ is a bounded weak solution of the Gauss-Codazzi system (2.6)–(2.7). Then the fundamental theorem of surface theory [27,28] implies an isometric realization of the corresponding two-dimensional Riemannian manifold in \mathbb{R}^3 . This completes the proof. \square

Remark 4.1. In the compensated compactness framework, Condition (A.1) can be relaxed to the following condition: For $p > 2$,

$$(A.1)' \quad \|(L^\varepsilon, M^\varepsilon, N^\varepsilon)\|_{L^p(\Omega)} \leq C, \quad \text{for some } C > 0 \text{ independent of } \varepsilon.$$

Then all the arguments for Theorem 4.1 follow only with the weak convergence in $L^p(\Omega)$, $p > 2$, replacing the weak-star convergence in $L^\infty(\Omega)$, with the aid of the Young measure representation theorem for a uniformly L^p bounded sequence of functions (cf. Ball [1]).

There are various ways to construct approximate solutions by either analytical methods, such as vanishing viscosity and relaxation, or numerical methods, such as finite difference schemes and finite elements. Even though the solution to the Gauss-Codazzi system may eventually turn out to be more regular, especially in the region of positive Gauss curvature $\kappa > 0$, the point of considering weak solutions here is to demonstrate that such solutions may be constructed by merely using very crude estimates. Such estimates are available in a variety of approximating methods through basic energy-type estimates, besides the L^∞ estimate. On the other hand, in the region of negative Gauss curvature $\kappa < 0$, discontinuous solutions are expected so that the estimates can be improved at most up to BV in general.

The compensated compactness framework (Theorem 4.1) indicates that, in order to find an isometric immersion, it suffices to construct a sequence of approximate solutions $(L^\varepsilon, M^\varepsilon, N^\varepsilon)(x, y)$ satisfying Framework (A), which yields its weak limit $(\bar{L}, \bar{M}, \bar{N})$ to be an isometric immersion. To achieve this through the fluid dynamic formulation

(3.1) and (3.3) (or (3.4)), a uniform L^∞ estimate of $(u^\varepsilon, v^\varepsilon)$ is required such that the sequence

$$(L^\varepsilon, M^\varepsilon, N^\varepsilon) = (\rho^\varepsilon (v^\varepsilon)^2 + p^\varepsilon, -\rho^\varepsilon u^\varepsilon v^\varepsilon, \rho^\varepsilon (u^\varepsilon)^2 + p^\varepsilon)$$

with

$$p^\varepsilon = -\frac{1}{\rho^\varepsilon} = \sqrt{(u^\varepsilon)^2 + (v^\varepsilon)^2 + \kappa}$$

satisfies Framework (A).

The fluid dynamic formulation, (3.1) and (3.3) (or (3.4)), and the compensated compactness framework (Theorem 4.1) provide a unified approach to deal with various isometric immersion problems even for the case when the Gauss curvature changes sign, that is, for the equations of mixed elliptic-hyperbolic type.

5. Isometric Immersions of Two-Dimensional Riemannian Manifolds with Negative Gauss Curvature

As a first example, in this section, we show how this approach can be applied to establish an isometric immersion of a two-dimensional Riemannian manifold with negative Gauss curvature in \mathbb{R}^3 .

5.1. Reformulation. In this case, $\kappa < 0$ in Ω and, more specifically,

$$\kappa = -\gamma^2, \quad \gamma > 0 \quad \text{in } \Omega.$$

For convenience, we assume $\gamma \in C^1$ in this section and rescale (L, M, N) in this case as

$$\tilde{L} = \frac{L}{\gamma}, \quad \tilde{M} = \frac{M}{\gamma}, \quad \tilde{N} = \frac{N}{\gamma},$$

so that (2.7) becomes

$$\tilde{L}\tilde{N} - \tilde{M}^2 = -1.$$

Then, without ambiguity, we redefine the “fluid variables” via

$$\tilde{L} = \rho v^2 + p, \quad \tilde{M} = -\rho uv, \quad \tilde{N} = \rho u^2 + p,$$

and set $q^2 = u^2 + v^2$, where we have still used (u, v, p, ρ) as the scaled variables and will use them hereafter (although they are different from those in §2–§4).

Then the equations in (2.6) possess the same form of balance laws of momentum:

$$\begin{aligned} \partial_x(\rho uv) + \partial_y(\rho v^2 + p) &= R_1, \\ \partial_x(\rho u^2 + p) + \partial_y(\rho uv) &= R_2, \end{aligned} \tag{5.1}$$

where

$$R_1 := -(\rho v^2 + p)\tilde{\Gamma}_{22}^{(2)} - 2\rho uv\tilde{\Gamma}_{12}^{(2)} - (\rho u^2 + p)\tilde{\Gamma}_{11}^{(2)}, \quad (5.2)$$

$$R_2 := -(\rho v^2 + p)\tilde{\Gamma}_{22}^{(1)} - 2\rho uv\tilde{\Gamma}_{12}^{(1)} - (\rho u^2 + p)\tilde{\Gamma}_{11}^{(1)}, \quad (5.3)$$

$$\tilde{\Gamma}_{11}^{(1)} = \Gamma_{11}^{(1)} + \frac{\gamma_x}{\gamma}, \quad \tilde{\Gamma}_{12}^{(1)} = \Gamma_{12}^{(1)} + \frac{\gamma_y}{2\gamma}, \quad \tilde{\Gamma}_{22}^{(1)} = \Gamma_{22}^{(1)},$$

$$\tilde{\Gamma}_{11}^{(2)} = \Gamma_{11}^{(2)}, \quad \tilde{\Gamma}_{12}^{(2)} = \Gamma_{12}^{(2)} + \frac{\gamma_x}{2\gamma}, \quad \tilde{\Gamma}_{22}^{(2)} = \Gamma_{22}^{(2)} + \frac{\gamma_y}{\gamma}.$$

Furthermore, the constraint $\tilde{L}\tilde{N} - \tilde{M}^2 = -1$ becomes

$$\rho pq^2 + p^2 = -1. \quad (5.4)$$

From $p = -\frac{1}{\rho}$ and (5.4), we have the ‘‘Bernoulli’’ relation:

$$\rho = \frac{1}{\sqrt{q^2 - 1}} \quad \text{or} \quad p = -\sqrt{q^2 - 1}, \quad (5.5)$$

which yields

$$u^2 = p(p - \tilde{N}), \quad v^2 = p(p - \tilde{L}), \quad (\tilde{M})^2 = (\tilde{N} - p)(\tilde{L} - p). \quad (5.6)$$

Then the last relation in (5.6) gives the relation for p in terms of $(\tilde{L}, \tilde{M}, \tilde{N})$, and the first two give the relations for (u, v) in terms of $(\tilde{L}, \tilde{M}, \tilde{N})$.

Similar to the calculation in §3, we can write down our ‘‘rotationality–continuity equations’’ as

$$\partial_x v - \partial_y u = -\frac{1}{\rho q^2} (vR_2 - uR_1) =: S_1, \quad (5.7)$$

$$\partial_x(\rho u) + \partial_y(\rho v) = \frac{v}{q^2} R_1 + \frac{u}{q^2} R_2 =: S_2. \quad (5.8)$$

Under the new scaling, the ‘‘sound’’ speed is

$$c^2 = p'(\rho) = \frac{1}{\rho^2} > 0. \quad (5.9)$$

Then the ‘‘Bernoulli’’ relation (3.3) yields

$$c^2 = q^2 - 1. \quad (5.10)$$

Therefore, $q > c$, and the ‘‘flow’’ is always supersonic, i.e., the system is purely hyperbolic.

5.2. *Riemann invariants.* In polar coordinates $(u, v) = (q \cos \theta, q \sin \theta)$, we use $q^2 = 1 + \frac{1}{\rho^2}$ and $\rho q^2 = \rho + \frac{1}{\rho}$ from (5.5) to obtain

$$\begin{aligned}
 R_1 &= -\rho q^2 \sin^2 \theta \tilde{\Gamma}_{22}^{(2)} - 2\rho q^2 \sin \theta \cos \theta \tilde{\Gamma}_{12}^{(2)} - \rho q^2 \cos^2 \theta \tilde{\Gamma}_{11}^{(2)} - \rho \left(\tilde{\Gamma}_{22}^{(2)} + \tilde{\Gamma}_{11}^{(2)} \right) \\
 &= -\left(\rho + \frac{1}{\rho} \right) \sin^2 \theta \tilde{\Gamma}_{22}^{(2)} - 2\rho q^2 \sin \theta \cos \theta \tilde{\Gamma}_{12}^{(2)} - \left(\rho + \frac{1}{\rho} \right) \cos^2 \theta \tilde{\Gamma}_{11}^{(2)} \\
 &\quad + \frac{1}{\rho} \left(\tilde{\Gamma}_{22}^{(2)} + \tilde{\Gamma}_{11}^{(2)} \right) \\
 &= -\rho \sin^2 \theta \tilde{\Gamma}_{22}^{(2)} + \frac{1}{\rho} \cos^2 \theta \tilde{\Gamma}_{22}^{(2)} - 2\rho q^2 \sin \theta \cos \theta \tilde{\Gamma}_{12}^{(2)} \\
 &\quad - \rho \cos^2 \theta \tilde{\Gamma}_{11}^{(2)} + \frac{1}{\rho} \sin^2 \theta \tilde{\Gamma}_{11}^{(2)} \\
 &= -\rho \left(1 - \cos^2 \theta \right) \tilde{\Gamma}_{22}^{(2)} + \frac{1}{\rho} \cos^2 \theta \tilde{\Gamma}_{22}^{(2)} \\
 &\quad - 2\rho q^2 \sin \theta \cos \theta \tilde{\Gamma}_{12}^{(2)} - \rho \left(1 - \sin^2 \theta \right) \tilde{\Gamma}_{11}^{(2)} + \frac{1}{\rho} \sin^2 \theta \tilde{\Gamma}_{11}^{(2)} \\
 &= \rho \left(1 + \frac{1}{\rho^2} \right) \cos^2 \theta \tilde{\Gamma}_{22}^{(2)} - 2\rho q^2 \sin \theta \cos \theta \tilde{\Gamma}_{12}^{(2)} + \rho \left(1 + \frac{1}{\rho^2} \right) \sin^2 \theta \tilde{\Gamma}_{11}^{(2)} \\
 &\quad - \rho \left(\tilde{\Gamma}_{22}^{(2)} + \tilde{\Gamma}_{11}^{(2)} \right) \\
 &= \rho q^2 \cos^2 \theta \tilde{\Gamma}_{22}^{(2)} - 2\rho q^2 \sin \theta \cos \theta \tilde{\Gamma}_{12}^{(2)} + \rho q^2 \sin^2 \theta \tilde{\Gamma}_{11}^{(2)} \\
 &\quad - \rho \left(\tilde{\Gamma}_{22}^{(2)} + \tilde{\Gamma}_{11}^{(2)} \right),
 \end{aligned}$$

and similarly,

$$R_2 = \rho q^2 \cos^2 \theta \tilde{\Gamma}_{22}^{(1)} - 2\rho q^2 \sin \theta \cos \theta \tilde{\Gamma}_{12}^{(1)} + \rho q^2 \sin^2 \theta \tilde{\Gamma}_{11}^{(1)} - \rho \left(\tilde{\Gamma}_{22}^{(1)} + \tilde{\Gamma}_{11}^{(1)} \right).$$

Then (5.7) and (5.8) become

$$\sin \theta \partial_x q + q \cos \theta \partial_x \theta - \cos \theta \partial_y q + q \sin \theta \partial_y \theta = S_1, \tag{5.11}$$

$$\frac{\cos \theta}{q(q^2 - 1)} \partial_x q + \sin \theta \partial_x \theta + \frac{\sin \theta}{q(q^2 - 1)} \partial_y q - \cos \theta \partial_y \theta = -\frac{\sqrt{q^2 - 1}}{q} S_2. \tag{5.12}$$

That is, as a first-order system, (5.7) and (5.8) can be written as

$$\begin{bmatrix} \sin \theta & q \cos \theta \\ \frac{1}{q(q^2-1)} \cos \theta & \sin \theta \end{bmatrix} \partial_x \begin{bmatrix} q \\ \theta \end{bmatrix} + \begin{bmatrix} -\cos \theta & q \sin \theta \\ \frac{1}{q(q^2-1)} \sin \theta & -\cos \theta \end{bmatrix} \partial_y \begin{bmatrix} q \\ \theta \end{bmatrix} = \begin{bmatrix} S_1 \\ -\frac{\sqrt{q^2-1}}{q} S_2 \end{bmatrix}. \tag{5.13}$$

One of our main observations is that, under this reformation, the two coefficient matrices in (5.13) actually commute, which guarantees that they have common eigenvectors. The eigenvalues of the first and second matrices are

$$\lambda_{\pm} = \sin \theta \pm \frac{\cos \theta}{\sqrt{q^2 - 1}}, \quad \mu_{\pm} = -\cos \theta \pm \frac{\sin \theta}{\sqrt{q^2 - 1}},$$

and the common left eigenvectors of the two coefficient matrices are

$$\left(\pm \frac{1}{q\sqrt{q^2 - 1}}, 1\right).$$

Thus, we may define the Riemann invariants $W_{\pm} = W_{\pm}(\theta, q)$ as

$$\partial_{\theta} W_{\pm} = 1, \quad \partial_q W_{\pm} = \pm \frac{1}{q\sqrt{q^2 - 1}}, \tag{5.14}$$

which yields

$$W_{\pm} = \theta \pm \arccos\left(\frac{1}{q}\right). \tag{5.15}$$

Now multiplication (5.13) by $(\partial_q W_{\pm}, \partial_{\theta} W_{\pm})$ from the left yields

$$\lambda_+ (\partial_q W_+ \partial_x q + \partial_{\theta} W_+ \partial_x \theta) + \mu_+ (\partial_q W_+ \partial_y q + \partial_{\theta} W_+ \partial_y \theta) = S_1 \partial_q W_+ - \frac{\sqrt{q^2 - 1}}{q} S_2, \tag{5.16}$$

$$\lambda_- (\partial_q W_- \partial_x q + \partial_{\theta} W_- \partial_x \theta) + \mu_- (\partial_q W_- \partial_y q + \partial_{\theta} W_- \partial_y \theta) = S_1 \partial_q W_- - \frac{\sqrt{q^2 - 1}}{q} S_2. \tag{5.17}$$

From (5.15),

$$\partial_x W_{\pm} = \partial_q W_{\pm} \partial_x q + \partial_{\theta} W_{\pm} \partial_x \theta, \quad \partial_y W_{\pm} = \partial_q W_{\pm} \partial_y q + \partial_{\theta} W_{\pm} \partial_y \theta,$$

and we can write (5.16) and (5.17) as

$$\lambda_+ \partial_x W_+ + \mu_+ \partial_y W_+ = \frac{1}{q\sqrt{q^2 - 1}} S_1 - \frac{\sqrt{q^2 - 1}}{q} S_2, \tag{5.18}$$

$$\lambda_- \partial_x W_- + \mu_- \partial_y W_- = -\frac{1}{q\sqrt{q^2 - 1}} S_1 - \frac{\sqrt{q^2 - 1}}{q} S_2. \tag{5.19}$$

5.3. Vanishing viscosity method via parabolic regularization. Now we introduce a vanishing viscosity method via parabolic regularization to obtain the uniform L^{∞} estimate by identifying invariant regions for the approximate solutions.

First, if \tilde{R}_1 and \tilde{R}_2 denote the additional terms that should be added to the right-hand side of the Gauss-Codazzi system (5.1), our choice is

$$\tilde{R}_1 = \varepsilon \partial_y^2(\rho v), \quad \tilde{R}_2 = \varepsilon \partial_y^2(\rho u), \tag{5.20}$$

which gives us the system of “viscous” parabolic regularization:

$$\begin{aligned} \partial_x(\rho uv) + \partial_y(\rho v^2 + p) &= R_1 + \varepsilon \partial_y^2(\rho v) = R_1 + \tilde{R}_1, \\ \partial_x(\rho u^2 + p) + \partial_y(\rho uv) &= R_2 + \varepsilon \partial_y^2(\rho u) = R_2 + \tilde{R}_2. \end{aligned} \tag{5.21}$$

From Eqs. (3.8) and (3.9), we see

$$\tilde{S}_1 = -\frac{1}{\rho q^2} (v\tilde{R}_2 - u\tilde{R}_1), \quad \tilde{S}_2 = \frac{1}{q^2} (v\tilde{R}_1 + u\tilde{R}_2) \tag{5.22}$$

should be added to S_1 and S_2 on the right-hand side of (3.8) and (3.9). In polar coordinates $(u, v) = (q \cos \theta, q \sin \theta)$, (5.31) becomes

$$\tilde{S}_1 = \varepsilon \frac{2}{\rho q} \partial_y \theta \partial_y(\rho q) + \varepsilon \partial_y^2 \theta, \quad \tilde{S}_2 = \varepsilon \frac{1}{q} \partial_y^2(\rho q) - \varepsilon \rho (\partial_y \theta)^2. \tag{5.23}$$

Note the identity

$$\begin{aligned} \varepsilon \partial_y^2 \left(\arccos \left(\frac{1}{q} \right) \right) &= \varepsilon \partial_y^2 (\operatorname{arccsc}(\rho q)) \\ &= -\varepsilon \partial_y \left(\frac{1}{\rho q \sqrt{\rho^2 q^2 - 1}} \right) \partial_y(\rho q) - \frac{\varepsilon}{\rho^2 q} \partial_y^2(\rho q) \\ &= -\varepsilon \partial_y \left(\frac{1}{\rho q \sqrt{\rho^2 q^2 - 1}} \right) \partial_y(\rho q) - \frac{\tilde{S}_2}{\rho^2} - \frac{\varepsilon}{\rho} (\partial_y \theta)^2. \end{aligned}$$

Then

$$\frac{\tilde{S}_2}{\rho^2} = -\varepsilon \partial_y^2 \left(\arccos \left(\frac{1}{q} \right) \right) - \varepsilon \partial_y \left(\frac{1}{\rho q \sqrt{\rho^2 q^2 - 1}} \right) \partial_y(\rho q) - \frac{\varepsilon}{\rho} (\partial_y \theta)^2,$$

and thus

$$\begin{aligned} \tilde{S}_1 - (q^2 - 1)\tilde{S}_2 &= \tilde{S}_1 - \frac{\tilde{S}_2}{\rho^2} = \frac{2\varepsilon}{\rho q} \partial_y \theta \partial_y(\rho q) + \varepsilon \partial_y^2 \theta + \varepsilon \partial_y^2 \left(\arccos \left(\frac{1}{q} \right) \right) \\ &\quad + \varepsilon \partial_y \left(\frac{1}{\rho q \sqrt{\rho^2 q^2 - 1}} \right) \partial_y(\rho q) + \frac{\varepsilon}{\rho} (\partial_y \theta)^2. \end{aligned}$$

Since

$$\partial_y \theta = \partial_y W_+ + \frac{\partial_y(\rho q)}{\rho q \sqrt{\rho^2 q^2 - 1}},$$

then

$$\tilde{S}_1 - (q^2 - 1)\tilde{S}_2 = \varepsilon \partial_y^2 W_+ + \frac{2\varepsilon q}{\rho} \partial_y W_+ \partial_y(\rho q) + \varepsilon (\partial_y W_+)^2.$$

Similarly, using

$$\partial_y \theta = \partial_y W_- - \frac{\partial_y(\rho q)}{\rho q \sqrt{\rho^2 q^2 - 1}},$$

we have

$$-\tilde{S}_1 - (q^2 - 1)\tilde{S}_2 = -\varepsilon \partial_y^2 W_- - \frac{2\varepsilon q}{\rho} \partial_y W_- \partial_y(\rho q) + \varepsilon (\partial_y W_-)^2.$$

Thus, if we add the above \tilde{S}_1 and \tilde{S}_2 to the original S_1 and S_2 , (5.18) and (5.19) become

$$\begin{aligned}
 & q\sqrt{q^2 - 1} \left(\lambda_+ \frac{\partial W_+}{\partial x} + \mu_+ \frac{\partial W_+}{\partial y} \right) \\
 &= \varepsilon \partial_y^2 W_+ + \frac{2\varepsilon q}{\rho} \partial_y W_+ \partial_y(\rho q) + \varepsilon(\partial_y W_+)^2 + S_1 - (q^2 - 1)S_2,
 \end{aligned} \tag{5.24}$$

$$\begin{aligned}
 & q\sqrt{q^2 - 1} \left(\lambda_- \frac{\partial W_-}{\partial x} + \mu_- \frac{\partial W_-}{\partial y} \right) \\
 &= -\varepsilon \partial_y^2 W_- - \frac{2\varepsilon q}{\rho} \partial_y W_- \partial_y(\rho q) + \varepsilon(\partial_y W_-)^2 - S_1 - (q^2 - 1)S_2.
 \end{aligned} \tag{5.25}$$

Substitution of R_1 and R_2 into S_1 and S_2 yields

$$\begin{aligned}
 & S_1 \pm (q^2 - 1)S_2 \\
 &= -q \sin \theta \left(\tilde{\Gamma}_{22}^{(1)} \cos^2 \theta - 2\tilde{\Gamma}_{12}^{(1)} \sin \theta \cos \theta + \tilde{\Gamma}_{11}^{(1)} \sin^2 \theta - \frac{1}{q^2} \left(\tilde{\Gamma}_{22}^{(1)} + \tilde{\Gamma}_{11}^{(1)} \right) \right) \\
 &\quad - q \cos \theta \left(-\tilde{\Gamma}_{22}^{(2)} \cos^2 \theta + 2\tilde{\Gamma}_{12}^{(2)} \sin \theta \cos \theta - \tilde{\Gamma}_{11}^{(2)} \sin^2 \theta + \frac{1}{q^2} \left(\tilde{\Gamma}_{22}^{(2)} + \tilde{\Gamma}_{11}^{(2)} \right) \right) \\
 &\pm \frac{1}{\rho} \left\{ q \cos \theta \left(\tilde{\Gamma}_{22}^{(1)} \cos^2 \theta - 2\tilde{\Gamma}_{12}^{(1)} \sin \theta \cos \theta + \tilde{\Gamma}_{11}^{(1)} \sin^2 \theta - \frac{1}{q^2} \left(\tilde{\Gamma}_{22}^{(1)} + \tilde{\Gamma}_{11}^{(1)} \right) \right) \right. \\
 &\quad \left. + q \sin \theta \left(\tilde{\Gamma}_{22}^{(2)} \cos^2 \theta - 2\tilde{\Gamma}_{12}^{(2)} \sin \theta \cos \theta + \tilde{\Gamma}_{11}^{(2)} \sin^2 \theta - \frac{1}{q^2} \left(\tilde{\Gamma}_{22}^{(2)} + \tilde{\Gamma}_{11}^{(2)} \right) \right) \right\}.
 \end{aligned} \tag{5.26}$$

Then system (5.24)–(5.25) is parabolic when $\lambda_+ > 0$ and $\lambda_- < 0$.

Furthermore, setting $(E, F, G) = (g_{11}, g_{12}, g_{22})$, we recall the following classical identities:

$$\begin{aligned}
 \Gamma_{11}^{(1)} &= \frac{GE_x - 2FF_x + FE_y}{2(EG - F^2)}, & \Gamma_{22}^{(1)} &= \frac{2GF_y - GG_x - FG_x}{2(EG - F^2)}, \\
 \Gamma_{11}^{(2)} &= \frac{2EF_x - EE_y - FE_x}{2(EG - F^2)}, & \Gamma_{22}^{(2)} &= \frac{EG_y - 2FF_y + FG_x}{2(EG - F^2)}, \\
 \Gamma_{12}^{(1)} &= \frac{GE_y - FG_x}{2(EG - F^2)}, & \Gamma_{12}^{(2)} &= \frac{EG_x - FE_y}{2(EG - F^2)},
 \end{aligned}$$

$$\begin{aligned}
 (EG - F^2)^2 \kappa &= \det \begin{bmatrix} -\frac{1}{2}E_{yy} + F_{xy} - \frac{1}{2}G_{xx} & \frac{1}{2}E_x & F_x - \frac{1}{2}F_y \\ F_x - \frac{1}{2}G_x & E & F \\ \frac{1}{2}G_y & F & G \end{bmatrix} \\
 &\quad - \det \begin{bmatrix} 0 & \frac{1}{2}E_y & \frac{1}{2}G_x \\ \frac{1}{2}E_y & E & F \\ \frac{1}{2}G_x & F & G \end{bmatrix},
 \end{aligned}$$

and $\gamma^2 = -\kappa$.

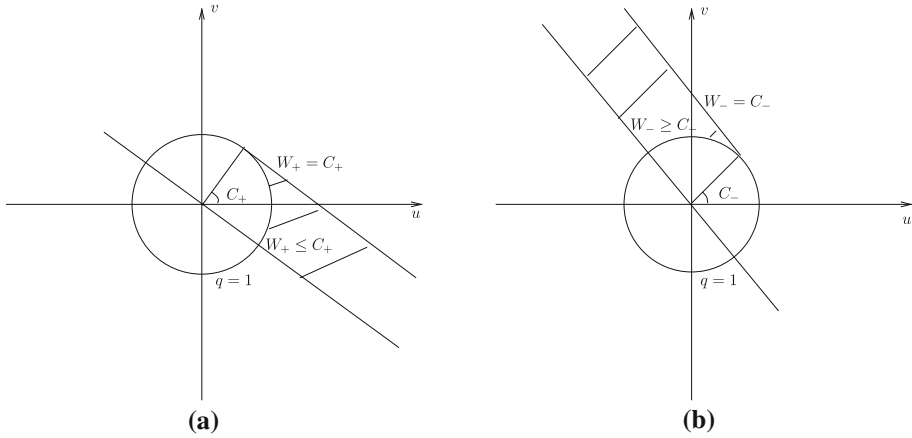

Fig. 1. Level sets $W_{\pm} = C_{\pm}$

5.4. L^{∞} -estimate for the viscous approximate solutions. Based on the calculation above for the Riemann invariants, we now introduce an approach to make the L^{∞} estimate. First we need to sketch the graphs of the level sets of W_{\pm} . In the $u - v$ plane, on $W_{\pm} = C_{\pm}$, we have

$$u \cos C_{\pm} + v \sin C_{\pm} = 1,$$

which shows that the level sets $W_{\pm} = C_{\pm}$ are straight lines as in Fig. 1.

As an example, we now focus on the case:

$$F = 0, \quad E(x) = G(x). \tag{5.27}$$

Then we see

$$\Gamma_{11}^{(1)} = \frac{E'}{2E}, \quad \Gamma_{12}^{(1)} = 0, \quad \Gamma_{22}^{(1)} = -\frac{E'}{2E}; \quad \Gamma_{11}^{(2)} = 0, \quad \Gamma_{12}^{(2)} = \frac{E'}{2E}, \quad \Gamma_{22}^{(2)} = 0.$$

Therefore, we have

$$\tilde{\Gamma}_{11}^{(1)} = \frac{E'}{2E} + \frac{\gamma'}{\gamma}, \quad \tilde{\Gamma}_{12}^{(1)} = 0, \quad \tilde{\Gamma}_{22}^{(1)} = -\frac{E'}{2E}; \quad \tilde{\Gamma}_{11}^{(2)} = 0, \quad \tilde{\Gamma}_{12}^{(2)} = \frac{E'}{2E} + \frac{\gamma'}{2\gamma}, \quad \tilde{\Gamma}_{22}^{(2)} = 0,$$

and (5.26) becomes

$$\begin{aligned} S_1 \pm (q^2 - 1)S_2 &= \frac{1}{2\gamma^2} \left(\frac{\kappa'}{\rho^2 q} - \gamma^2 q \frac{E'}{E} \right) \sin \theta \mp \frac{1}{2\gamma^2 \rho} \left(-\frac{\kappa'}{q} + q\gamma^2 \frac{E'}{E} \right) \cos \theta \\ &= -\frac{q}{2} \left(\frac{E'}{E} + \frac{1}{\rho^2 q^2} \frac{\kappa'}{\kappa} \right) \sin \theta \mp \frac{q}{2\rho} \left(\frac{E'}{E} + \frac{1}{q^2} \frac{\kappa'}{\kappa} \right) \cos \theta. \end{aligned} \tag{5.28}$$

Define $\theta_{\pm}(q)$ by

$$\tan \theta_{\pm} = \pm \frac{-\left(\frac{E'}{E} + \frac{1}{q^2} \frac{\kappa'}{\kappa}\right)}{\rho \left(\frac{E'}{E} + \frac{1}{\rho^2 q^2} \frac{\kappa'}{\kappa}\right)} = \mp \frac{\frac{E'}{E} + \frac{1}{q^2} \frac{\kappa'}{\kappa}}{\rho \left(\frac{E'}{E} + \frac{1}{\rho^2 q^2} \frac{\kappa'}{\kappa}\right)}. \tag{5.29}$$

Then, at the critical points of W_+ , (5.24) becomes

$$\varepsilon \partial_y^2 W_+ + \frac{q}{2} \left(\frac{E'}{E} + \frac{1}{\rho^2 q^2} \frac{\kappa'}{\kappa} \right) (\tan \theta_- - \tan \theta) \cos \theta = 0, \tag{5.30}$$

and, at the critical points of W_- , (5.25) becomes

$$-\varepsilon \partial_y^2 W_- + \frac{q}{2} \left(\frac{E'}{E} + \frac{1}{\rho^2 q^2} \frac{\kappa'}{\kappa} \right) (\tan \theta - \tan \theta_+) \cos \theta = 0. \tag{5.31}$$

If we fix the intersection point of $\theta_{\pm}(q)$ at

$$\theta = 0, \quad q = \beta,$$

where $\beta > 1$ is a constant, then the above ordinary differential equation (5.29) becomes

$$\frac{1}{\beta^2} \frac{\kappa'(x)}{\kappa(x)} + \frac{E'(x)}{E(x)} = 0, \tag{5.32}$$

i.e.,

$$\frac{d}{dx} \ln(|\kappa(x)|^{\frac{1}{\beta^2}} E(x)) = 0.$$

Thus, we find

$$|\kappa(x)|^{\frac{1}{\beta^2}} E(x) = \text{const.} > 0.$$

Since $\kappa(x) < 0$, then

$$\kappa(x) = -\kappa_0 E(x)^{-\beta^2},$$

where $\kappa_0 > 0$ is a constant, and Eq. (5.29) becomes

$$\tan \theta_{\pm} = \pm \frac{\sqrt{q^2 - 1}(\beta^2 - q^2)}{\beta^2 - (\beta^2 - 1)q^2}. \tag{5.33}$$

In (5.33), if $\beta^2 - (\beta^2 - 1)q^2 = 0$, we define the associated root as

$$q = q_0 := \left(\frac{\beta^2}{\beta^2 - 1} \right)^{\frac{1}{2}}.$$

The denominator $\beta^2 - (\beta^2 - 1)q^2 < 0$ if $q > q_0$. We also desire $q_0 < \beta$, which is ensured if $\beta > \sqrt{2}$. The curves $\theta_{\pm}(q)$ are independent of (x, y) and look like the sketch in Fig. 2.

Assume that we have a solution $E(x)$ to (5.32). It is easy to check that the term $\frac{E'}{E} + \frac{1}{\rho^2 q^2} \frac{\kappa'}{\kappa}$ in (5.30) and (5.31) has the sign of $-E'(x)$ when $q > q_0$, since

$$\frac{E'}{E} + \frac{1}{\rho^2 q^2} \frac{\kappa'}{\kappa} = \frac{-E'}{E q^2} (\beta^2 - 1)(q^2 - q_0^2).$$

For the moment, we assume $-E' > 0$. Fix another constant α with $q_0 < \alpha < \beta$, and sketch the W_{\pm} lines and the diamond-shaped region as in Fig. 3.

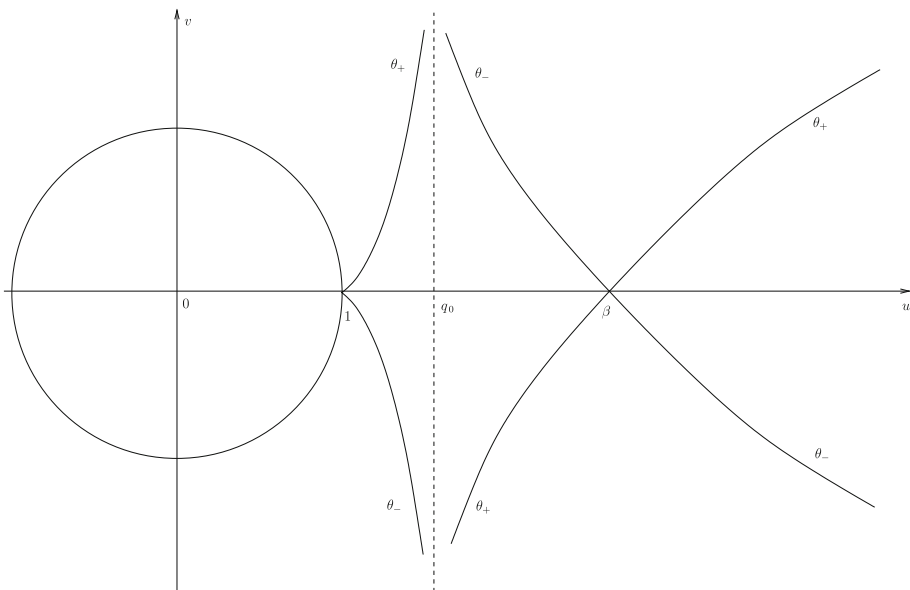

Fig. 2. Graphs of θ_{\pm} for $\beta > \sqrt{2}$

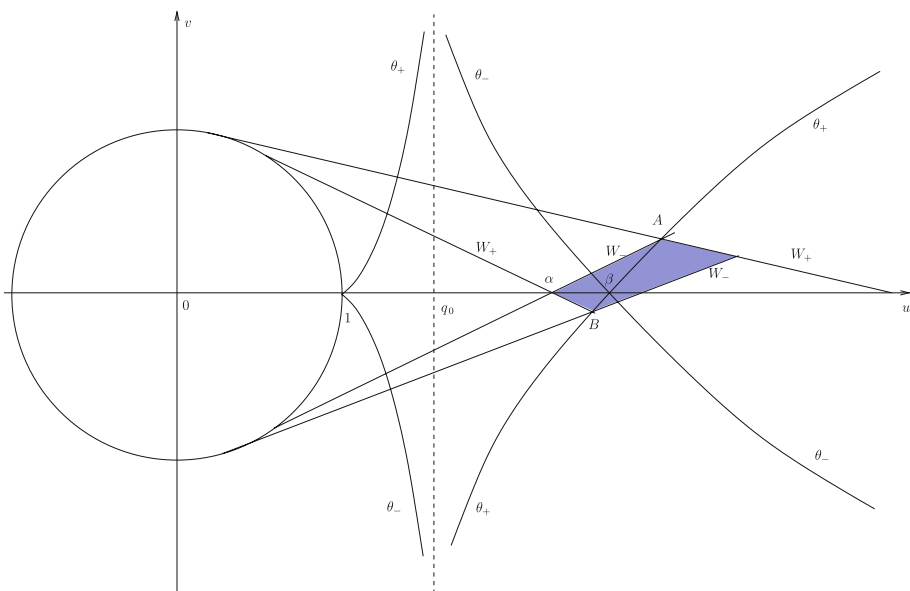

Fig. 3. Invariant regions

Since $\cos \theta > 0$ for $\theta \in (-\frac{\pi}{2}, \frac{\pi}{2})$, Eqs. (5.30) and (5.31) imply that, at any point where $\nabla W_+ = 0$ (respectively $\nabla W_- = 0$),

$$\varepsilon \partial_y^2 W_{\pm} \begin{cases} > 0 & \text{for } \theta > \theta_-(q), \\ < 0 & \text{for } \theta < \theta_-(q), \end{cases}$$

$$\varepsilon \partial_y^2 W_- \begin{cases} > 0 & \text{for } \theta > \theta_+(q), \\ < 0 & \text{for } \theta < \theta_+(q). \end{cases}$$

Hence, when $\lambda_+ > 0$ and $\lambda_- < 0$, by the parabolic maximum principle (cf. [19,35]),

- W_+ has no internal maximum for $\theta > \theta_-(q)$,
- W_+ has no internal minimum for $\theta < \theta_-(q)$,
- W_- has no internal maximum for $\theta > \theta_+(q)$,
- W_- has no internal minimum for $\theta < \theta_+(q)$.

We will be able to conclude that the diamond-shaped region in Fig. 3 is an invariant region if we can show that it is contained in the strip where $\lambda_+ > 0$ and $\lambda_- < 0$. We will do this as follows.

Recall that $\partial_\theta W_\pm = 1$, then W_\pm are increasing with increasing θ on any circle $q = \text{constant}$. In Fig. 3, we require that the line with constant W_- through $u = \alpha, v = 0$ intersect the curve θ_+ , which is ensured if α is close to β due to the following calculations. The slope of curve θ_+ at $u = \beta, v = 0$ can be computed from

$$\tan \theta_+ = \frac{v}{u} = \frac{\sqrt{q^2 - 1}(\beta^2 - q^2)}{\beta^2 - (\beta^2 - 1)q^2},$$

which implies

$$v = \frac{u\sqrt{q^2 - 1}}{\beta^2 - (\beta^2 - 1)q^2}(\beta^2 - q^2),$$

and thus

$$\left. \frac{dv}{du} \right|_{u=\beta, v=0} = \frac{2\sqrt{\beta^2 - 1}}{\beta^2 - 2} > 0 \quad \text{for } \beta > \sqrt{2}.$$

The slope of the line W_- through $u = \beta, v = 0$ can be computed from the equation of the level set:

$$\theta - \arccos\left(\frac{1}{q}\right) = W_-(0, \beta) = -\arccos(\beta^{-1}),$$

that is,

$$\frac{d}{du} \left(\arctan\left(\frac{v}{u}\right) - \arccos\left(\frac{1}{q}\right) \right) = 0,$$

which gives us

$$\left. \frac{dv}{du} \right|_{u=\beta, v=0} = \frac{1}{\sqrt{\beta^2 - 1}}.$$

So the intersection will occur if

$$\frac{2\sqrt{\beta^2 - 1}}{\beta^2 - 2} > \frac{1}{\sqrt{\beta^2 - 1}},$$

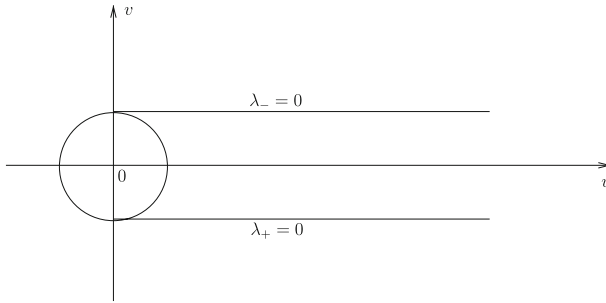

Fig. 4. Graphs of $\lambda_{\pm} = 0$

i.e., $2(\beta^2 - 1) > \beta^2 - 2$, which always holds for nonzero β . Thus, locally near β , the desired intersection occurs. A similar argument shows that the line with constant W_+ intersects the curve θ_- locally near β .

From the definition of λ_{\pm} :

$$\lambda_{\pm} = \sin \theta \pm \frac{\cos \theta}{\sqrt{q^2 - 1}},$$

we easily see that the lines $\lambda_{\pm} = 0$ are $v = \pm 1, u > 0$, as sketched in Fig. 4. Notice that $\lambda_+ > 0$ and $\lambda_- < 0$ are in the region above $\lambda_+ = 0$ and below $\lambda_- = 0$. If we now super-impose Fig. 3 on top of Fig. 4 and choose appropriate α and β , we see that there is a region where the four-sided (diamond-shaped) region of Fig. 3 is entirely confined above $\lambda_+ = 0$ and below $\lambda_- = 0$ in Fig. 4. Hence, the parabolic maximum/minimum principles apply and the four-sided region is an invariant region.

All these arguments yield the uniform L^∞ bounds for $(u^\varepsilon, v^\varepsilon, p^\varepsilon, \rho^\varepsilon)$, which implies

$$|(L^\varepsilon, M^\varepsilon, N^\varepsilon)| \leq C,$$

for some constant $C > 0$ depending only on the data and $\|\gamma\|_{L^\infty}$.

Finally, let us examine the following examples:

Example 5.1. Catenoid: $E(x) = (\cosh(cx))^{\frac{2}{\beta^2-1}}, \kappa(x) = -\kappa_0 E(x)^{-\beta^2}$, where $c \neq 0$ and $\kappa_0 > 0$ are two constants. Note that, in this example, $E'(x) > 0$ for $x > 0$ and $E'(x) < 0$ for $x < 0$. So our hypothesis for the invariant region $-E'(x) > 0$ will hold when $x < 0$. For the relevant parabolic equation for x time-like in the half plane $\Omega = \{(x, y) : -x_0 \leq x \leq 0, y \in \mathbb{R}\}$, where $x_0 > 0$ is arbitrary, with periodic initial data $(q(-x_0, y), \theta(-x_0, y))$ in the four sided region, the parabolic maximum/minimum principles yield the invariant region for the y -periodic solution. These arguments yield the uniform L^∞ bounds for $(u^\varepsilon, v^\varepsilon, p^\varepsilon, \rho^\varepsilon)$ which implies that $|(L^\varepsilon, M^\varepsilon, N^\varepsilon)| \leq C$ for some constant $C > 0$ depending only on the initial data and of course the given metric (E, F, G) with $E(x) = G(x), F \equiv 0$. We must give the initial data on the line $x = -x_0 < 0$.

Example 5.2. Helicoid: The metric associated with the helicoid is

$$ds^2 = E(dX)^2 + (dY)^2$$

with $E(Y) = \lambda^2 + Y^2$ and the Gauss curvature

$$\kappa = -\frac{\lambda^2}{(\lambda^2 + Y^2)^2},$$

where $\lambda > 0$ is a constant. We make a change of variables to rewrite the helicoid metric in isothermal coordinates, i.e., allow X, Y to depend on x, y so that

$$ds^2 = (EX_x^2 + Y_x^2)dx^2 + 2(EX_xX_y + Y_xY_y)dxdy + (EX_y^2 + Y_y^2)dy^2.$$

Hence, if we set

$$Y_x = -\sqrt{E}X_y, \quad Y_y = \sqrt{E}X_x,$$

then

$$ds^2 = E(X_x^2 + X_y^2)(dx^2 + dy^2),$$

which gives the metric in isothermal coordinates. The above equations for X and Y may be rewritten as

$$-\frac{Y_x}{\sqrt{E}} = X_y, \quad \frac{Y_y}{\sqrt{E}} = X_x,$$

and with

$$\phi(Y) = \int \frac{dY}{\sqrt{\lambda^2 + Y^2}} = \ln(Y + \sqrt{\lambda^2 + Y^2}).$$

Then we have

$$-\phi_x = X_y, \quad \phi_y = X_x,$$

i.e., the Cauchy-Riemann equations. A convenient solution is given by

$$\phi = -x, \quad X = y,$$

which yields

$$-x = \ln(Y + \sqrt{\lambda^2 + Y^2}),$$

that is,

$$Y = -\frac{1}{2}(\lambda^2 e^x - e^{-x}).$$

Thus, in the new (x, y) -coordinates,

$$E = \lambda^2 + Y^2 = \frac{1}{2}\lambda^2 + \frac{1}{4}(\lambda^4 e^{2x} + e^{-2x}), \quad \kappa = \frac{-\lambda^2}{(\lambda^2 + Y^2)^2} = \frac{-\lambda^2}{\left(\frac{1}{2}\lambda^2 + \frac{1}{4}(\lambda^4 e^{2x} + e^{-2x})\right)^2},$$

and

$$ds^2 = \left(\frac{1}{2}\lambda^2 + \frac{1}{4}(\lambda^4 e^{2x} + e^{-2x})\right)(dx^2 + dy^2).$$

Hence, we have

$$-\frac{2E'(x)}{E(x)} = \frac{\kappa'(x)}{\kappa(x)},$$

and so relation (5.32) is satisfied with $\beta = \sqrt{2}$, thus

$$\tan \theta_{\pm} = \pm \sqrt{q^2 - 1},$$

the graphs of θ_{\pm} never intersect, and thus our method of invariant regions does not apply to this example.

Example 5.3. Torus: The metric for the torus is usually written as

$$ds^2 = EdX^2 + b^2dY^2$$

with

$$E = (a + b \cos Y)^2, \quad \kappa(Y) = \frac{\cos Y}{b(a + b \cos Y)},$$

where $a > b > 0$ are constants. The same argument as given in Example 5.2 above yields the metric in isothermal coordinates as

$$ds^2 = E(dx^2 + dy^2)$$

with

$$E = (a + b \cos Y)^2 = (a + b \cos(\phi^{-1}(x))^2),$$

where

$$\phi(Y) = \frac{b}{\sqrt{a^2 - b^2}} \arctan\left(\frac{\sqrt{a^2 - b^2} \sin Y}{b + a \cos Y}\right),$$

$$\kappa(x) = \frac{\cos Y}{b(a + b \cos Y)} = \frac{\cos(\phi^{-1}(x))}{b(a + b \cos(\phi^{-1}(x)))}.$$

A direct calculation yields

$$\frac{\kappa'(x)}{\kappa(x)} = -\frac{a(\phi^{-1}(x))' \tan(\phi^{-1}(x))}{a + b \cos(\phi^{-1}(x))}, \quad \frac{E'(x)}{E(x)} = -\frac{b(\phi^{-1}(x))' \sin(\phi^{-1}(x))}{a + b \cos(\phi^{-1}(x))},$$

and the ratio

$$\frac{\kappa'(x)}{\kappa(x)} \bigg/ \frac{E'(x)}{E(x)} = \frac{a}{b \cos(\phi^{-1}(x))}$$

is not a constant. So (5.32) does not hold and unfortunately our method of invariant regions does not apply.

5.5. H_{loc}^{-1} -compactness. We now show how the H_{loc}^{-1} -compactness can be achieved for the viscous periodic approximate solutions via parabolic regularization.

In §5.4, Example 5.1, for any initial data in the four-sided region which is periodic in y with period P , we have a uniform L^∞ estimate on $(u^\varepsilon, v^\varepsilon, p^\varepsilon, \rho^\varepsilon)$ as the periodic solution to the viscous equations (5.21). From the equations in (5.23), we have

$$\begin{aligned} \partial_x(\rho u) + \partial_y(\rho v) &= \frac{v}{q^2} R_1 + \frac{u}{q^2} R_2 + \varepsilon \frac{1}{q} \frac{\partial^2}{\partial y^2}(\rho q) - \varepsilon \rho(\partial_y \theta)^2 \\ &= B(x, y) + \varepsilon \frac{1}{q} \frac{\partial^2}{\partial y^2}(\rho q) - \varepsilon \rho(\partial_y \theta)^2, \end{aligned} \tag{5.34}$$

where

$$\begin{aligned} B(x, y) &= \frac{\rho}{q} \sin \theta \left(- \left(\rho q^2 \sin^2 \theta - \frac{1}{\rho} \right) \tilde{\Gamma}_{22}^{(2)} - \rho q^2 \sin(2\theta) \tilde{\Gamma}_{12}^{(2)} - \left(\rho q^2 \cos^2 \theta - \frac{1}{\rho} \right) \tilde{\Gamma}_{11}^{(2)} \right) \\ &\quad + \frac{\rho}{q} \cos \theta \left(- \left(\rho q^2 \sin^2 \theta - \frac{1}{\rho} \right) \tilde{\Gamma}_{22}^{(1)} - \rho q^2 \sin(2\theta) \tilde{\Gamma}_{12}^{(1)} - \left(\rho q^2 \cos^2 \theta - \frac{1}{\rho} \right) \tilde{\Gamma}_{11}^{(1)} \right). \end{aligned}$$

Our L^∞ estimate in §5.4, Example 5.1, guarantees that $B(x, y)$ is uniformly bounded with respect to ε .

Using the periodicity, we find that, for any fixed $x_0 > 0$,

$$\begin{aligned} \int_{-x_0}^0 \int_0^P \frac{1}{q} \frac{\partial^2}{\partial y^2}(\rho q) dy dx &= \int_{-x_0}^0 \int_0^P \frac{\partial_y q}{q^2} \partial_y(\rho q) dy dx \\ &= \int_{-x_0}^0 \int_0^P \frac{\partial_y q}{q^2} \left(-\rho^3 \partial_y q \right) dy dx = - \int_{-x_0}^0 \int_0^P \frac{\rho^3 (\partial_y q)^2}{q^2} dy dx. \end{aligned}$$

Now integrating both sides of (5.34) over $\Omega = \{(x, y) : -x_0 \leq x \leq 0, 0 \leq y \leq P\}$, we find

$$\begin{aligned} \varepsilon \int_{-x_0}^0 \int_0^P \left(\frac{\rho^3 (\partial_y q)^2}{q^2} + \rho (\partial_y \theta)^2 \right) dy dx \\ &= \int_{-x_0}^0 \int_0^P B(x, y) dy dx - \int_0^P ((\rho u)(0, y) - (\rho u)(x_0, y)) dy \\ &\leq C, \end{aligned}$$

where $C > 0$ is independent of ε , but may depend on x_0 and P . This implies that

$$\sqrt{\varepsilon} \partial_y \theta, \sqrt{\varepsilon} \partial_y q \quad \text{are in } L^2_{loc}(\Omega) \text{ uniformly in } \varepsilon.$$

Therefore, we have

Proposition 5.1. *Consider the viscous system (5.21) in $\Omega = \{(x, y) : -x_0 \leq x \leq 0, y \in \mathbb{R}\}$ with periodic initial data $(q, \theta)|_{x=-x_0} = (q_0(y), \theta_0(y))$. Then*

$$\sqrt{\varepsilon} \partial_y q, \sqrt{\varepsilon} \theta_y \quad \text{are in } L^2_{loc}(\Omega) \text{ uniformly in } \varepsilon.$$

Using Proposition 5.1 and the viscous system (5.21), we conclude that

$$\partial_x \tilde{M}^\varepsilon - \partial_y \tilde{L}^\varepsilon, \quad \partial_x \tilde{N}^\varepsilon - \partial_y \tilde{M}^\varepsilon \quad \text{are compact in } H_{loc}^{-1}(\Omega).$$

Since $\gamma \in C^1$, we conclude that $(L^\varepsilon, M^\varepsilon, N^\varepsilon)(x, y) = \gamma(x)(\tilde{L}^\varepsilon, \tilde{M}^\varepsilon, \tilde{N}^\varepsilon)(x, y)$ satisfies Framework (A) in §4. Then the compensated compactness framework (Theorem 4.1) implies that there is a subsequence (still labeled) $(L^\varepsilon, M^\varepsilon, N^\varepsilon)(x, y)$ that converges weak-star to $(\bar{L}, \bar{M}, \bar{N})$ as $\varepsilon \rightarrow 0$ such that the limit $(\bar{L}, \bar{M}, \bar{N})$ is a bounded, periodic weak solution to the Gauss-Codazzi system (2.6)–(2.7). Therefore, $(\bar{L}, \bar{M}, \bar{N})$ is a weak solution of (2.6)–(2.7). We summarize this as Proposition 5.2.

Proposition 5.2. *For the initial value problem of Proposition 5.1, $(L^\varepsilon, M^\varepsilon, N^\varepsilon)$ possesses a weak-star convergent subsequence that converges to a periodic weak solution of the associated initial value problem for the Gauss-Codazzi system (2.6)–(2.7) when $\varepsilon \rightarrow 0$.*

5.6. *Existence of isometric immersions: Main theorem and examples.* We now focus on the case (5.27):

$$F = 0, \quad \text{and } E = G \text{ depends only on } x$$

to state an existence result for isometric immersions and analyze examples for this case.

Let us look for a special solution:

$$(\theta, q) = (0, \beta) \quad (\text{constant state}),$$

for the Gauss-Codazzi system for the case (5.27). In this case,

$$\tilde{\Gamma}_{11}^{(1)} = \frac{E'}{2E} + \frac{\gamma'}{\gamma}, \quad \tilde{\Gamma}_{12}^{(1)} = 0, \quad \tilde{\Gamma}_{22}^{(1)} = -\frac{E'}{2E}; \quad \tilde{\Gamma}_{11}^{(2)} = 0, \quad \tilde{\Gamma}_{12}^{(2)} = \frac{E'}{2E} + \frac{\gamma'}{2\gamma}, \quad \tilde{\Gamma}_{22}^{(2)} = 0,$$

and the Gauss-Codazzi system (5.1) becomes

$$\begin{aligned} \partial_x \left(\frac{1}{\rho} \right) &= -p \frac{E'}{2E} + (\rho q^2 + p) \left(\frac{E'}{2E} + \frac{\gamma'}{\gamma} \right) = \rho q^2 \frac{E'}{2E} + (\rho q^2 + p) \frac{\gamma'}{\gamma} \\ \rho &= \frac{1}{\sqrt{q^2 - 1}} = \rho q^2 \frac{E'}{2E} + \rho \frac{\gamma'}{\gamma}. \end{aligned}$$

When $q(x) \equiv \beta$, this reduces to

$$\frac{1}{\beta^2} \frac{\gamma'}{\gamma} = -\frac{E'}{2E},$$

or

$$\frac{1}{\beta^2} \frac{\kappa'(x)}{\kappa(x)} = -\frac{E'}{E}. \tag{5.35}$$

Hence, $q(x) = \beta$ becomes an exact solution precisely in this special case. Our theorem given below shows that, in fact, the prescribed initial conditions in this special case can be satisfied and that, for this choice of E, F, G , there exists a weak solution for arbitrary bounded data in our diamond-shaped region (see Figs. 3–4) (especially when $\alpha \in (1, \beta)$ is sufficiently close to β).

Theorem 5.1. For the catenoid with the metric $E(x) = G(x) = (\cosh(cx))^{\frac{2}{\beta^2-1}}$, $F(x) = 0$, $c \neq 0$, and $\beta > \sqrt{2}$ in Example 5.1, assume that the initial data

$$(q, \theta)|_{x=-x_0} = (q_0(y), \theta_0(y)) := (q(-x_0, y), \theta(-x_0, y)) \tag{5.36}$$

is L^∞ and lies in the diamond-shaped region of Figs. 3–4. Then the Gauss-Codazzi system (2.6)–(2.7) has a weak solution in $\Omega = \{(x, y) : -x_0 \leq x \leq 0, y \in \mathbb{R}\}$ with the initial data (5.36).

Proof. Step 1. For the initial data $(q_0(y), \theta_0(y))$, we can find $(q_0^P(y), \theta_0^P(y))$ for $P > 0$ such that

- (i) $q_0^P, \theta_0^P \in C^1(\mathbb{R})$, q_0^P, θ_0^P are periodic with period P ;
- (ii) $q_0^P \rightarrow q_0, \theta_0^P \rightarrow \theta_0$ a.e. in \mathbb{R} and weakly in $L^\infty(\mathbb{R})$ as $P \rightarrow \infty$.

In particular, the functions q_0^P and θ_0^P are bounded in $L^\infty(\mathbb{R})$, and (q_0^P, θ_0^P) converges to (q_0, θ_0) in $L^p_{loc}(\mathbb{R})$, $p \in [1, \infty)$, as $P \rightarrow \infty$.

This can be achieved by the standard symmetric mollification procedure: First truncate the initial data $(W_{-,0}, W_{+,0}) = (W_-(q_0, \theta_0), W_+(q_0, \theta_0))$ in the interval $-\frac{P}{2} \leq y \leq \frac{P}{2}$ and make the periodic extension to the whole space $y \in \mathbb{R}$, and then take the standard symmetric mollification approximation to get the C^∞ approximate sequence $(W_{-,0}^P, W_{+,0}^P)$ that yields the corresponding C^∞ approximate sequence

$$(q_0^P, \theta_0^P) = \left(\left(\cos \left(\frac{W_{+,0}^P - W_{-,0}^P}{2} \right) \right)^{-1}, \frac{W_{+,0}^P + W_{-,0}^P}{2} \right)$$

converging to $(q_0, \theta_0) = ((\cos(\frac{W_{+,0}-W_{-,0}}{2}))^{-1}, \frac{W_{+,0}+W_{-,0}}{2})$ a.e. in \mathbb{R} as $P \rightarrow \infty$. Since the standard symmetric mollification is an average-smoothing operator, then the approximate sequence (q_0^P, θ_0^P) still lies in our diamond-shaped region of Figs. 3–4.

Step 2. Following the arguments in Sect. 5.4, we can establish the uniform L^∞ a priori estimates for the corresponding viscous solutions in two parameters $\epsilon > 0$ and $P > 0$. For fixed P , then we can show that there exists a unique periodic viscous solution with period P to the parabolic system (5.21), which can be achieved by combining the standard local existence theorem with the L^∞ estimates. The H_{loc}^{-1} -compactness follows from the argument in §5.5.

For fixed P , letting the viscous coefficient ϵ tend 0, we employ Proposition 5.2 to obtain the global periodic weak solution (L^P, M^P, N^P) of the Gauss-Codazzi system (2.6)–(2.7), periodic in y with period P , in the region $\Omega = \{(x, y) : -x_0 \leq x \leq 0, y \in \mathbb{R}\}$.

Step 3. Since the sequence of periodic solutions (L^P, M^P, N^P) still stays in the invariant region, which yields the uniform L^∞ bound in P as $P \rightarrow \infty$. This uniform bound also yields the H_{loc}^{-1} -compactness of

$$\partial_x \tilde{M}^P - \partial_y \tilde{L}^P, \quad \partial_x \tilde{N}^P - \partial_y \tilde{M}^P.$$

Using the compensated compactness framework (Theorem 4.1) again and letting $P \rightarrow \infty$, we obtain a global weak solution (L, M, N) of the Gauss-Codazzi system (2.6)–(2.7) in the region $\Omega = \{(x, y) : -x_0 \leq x \leq 0, y \in \mathbb{R}\}$. \square

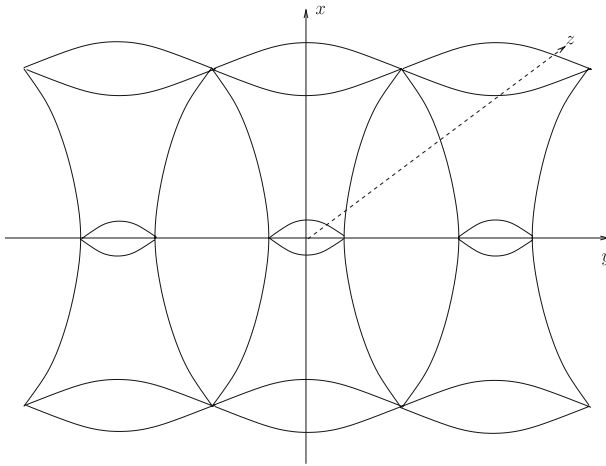

Fig. 5. $C^{1,1}$ -catenoid in the (x, y, z) -coordinates

By the even symmetry of the problem, we can obtain again a weak solution on the domain $0 \leq x \leq x_0, y \in \mathbb{R}$. Together, they form a weak solution in $-x_0 \leq x \leq x_0, y \in \mathbb{R}$ if the same data is prescribed at $x = x_0$ and $x = -x_0$. As before, the associated immersion is in $C^{1,1}$.

Theorem 5.2. *Assume that identical initial data (5.36) is prescribed at $x = x_0$ and $x = -x_0$, where $x_0 > 0$ is arbitrary, and the data is in L^∞ and lies in the diamond-shaped region of Figs. 3–4 for the case of the catenoid (as given in Theorem 5.1), then the initial value problem (2.6)–(2.7) and (5.36) has a weak solution in $L^\infty([-x_0, x_0] \times \mathbb{R})$. This yields a $C^{1,1}([-x_0, x_0] \times \mathbb{R})$ immersion of the Riemannian manifold into \mathbb{R}^3 .*

Remark 5.1. The catenoid with circular cross-section is sketched in Fig. 5. Our theorem asserts the existence of a $C^{1,1}$ -surface for the associated metric for a class of identical non-circular cross-sections prescribed at $x = x_0$ and $x = -x_0$. Since we give periodic cross sections $z = z(y)$ at $x = -x_0$, our theorem yields a sequence of catenoid-like surfaces.

Acknowledgements. This paper was completed when the authors attended the “Workshop on Nonlinear PDEs of Mixed Type Arising in Mechanics and Geometry”, which was held at the American Institute of Mathematics, Palo Alto, California, March 17–21, 2008. Gui-Qiang Chen’s research was supported in part by the National Science Foundation under Grants DMS-0807551, DMS-0720925, and DMS-0505473. Marshall Slemrod’s research was supported in part by the National Science Foundation under Grant DMS-0647554. Dehua Wang’s research was supported in part by the National Science Foundation under Grant DMS-0604362, and by the Office of Naval Research under Grant N00014-07-1-0668.

References

1. Ball, J.M.: *A version of the fundamental theorem for Young measures*. Lecture Notes in Phys. **344**, Berlin: Springer, 1989, pp. 207–215
2. Bers, L.: *Mathematical Aspects of Subsonic and Transonic Gas Dynamics*. New York: John Wiley & Sons, Inc., London: Chapman & Hall, Ltd., 1958
3. Chen, G.-Q.: Convergence of the Lax-Friedrichs scheme for isentropic gas dynamics (III). *Acta Math. Sci.* **6**, 75–120 (1986) (in English); **8**, 243–276 (1988) (in Chinese)

4. Chen, G.-Q.: Euler equations and related hyperbolic conservation laws. In: *Handbook of Differential Equations: Evolutionary Differential Equations*, Vol. 2, Eds. Dafermos, C.M., Feireisl, E., Amsterdam: Elsevier Science B.V, 2005 pp. 1–104
5. Chen, G.-Q., Dafermos, C.M., Slemrod, M., Wang, D.: On two-dimensional sonic-subsonic flow. *Commun. Math. Phys.* **271**, 635–647 (2007)
6. Chen, G.-Q., LeFloch, Ph.: Compressible Euler equations with general pressure law. *Arch. Rat. Mech. Anal.* **153**, 221–259 (2000); Existence theory for the isentropic Euler equations. *Arch. Rat. Mech. Anal.* **166**, 81–98 (2003)
7. Chen, G.-Q., Slemrod, M., Wang, D.: Vanishing viscosity method for transonic flow. *Arch. Rat. Mech. Anal.* **189**, 159–188 (2008)
8. Chen, G.-Q., Slemrod, M., Wang, D.: Weak continuity of the Gauss-Codazzi-Ricci system for isometric embedding. *Proc. Amer. Math. Soc.* 2009 (to appear)
9. Courant, R., Friedrichs, K.O.: *Supersonic Flow and Shock Waves*. New York: Springer, 1948
10. Dafermos, C.M.: *Hyperbolic Conservation Laws in Continuum Physics*. 2nd edition, Berlin: Springer-Verlag, 2005
11. Ding, X., Chen, G.-Q., Luo, P.: Convergence of the Lax-Friedrichs scheme for isentropic gas dynamics (I)-(II). *Acta Math. Sci.* **5**, 483–500, 501–540 (1985) (in English); **7**, 467–480 (1987), **8**, 61–94 (1988) (in Chinese)
12. DiPerna, R.J.: Convergence of viscosity method for isentropic gas dynamics. *Commun. Math. Phys.* **91**, 1–30 (1983)
13. DiPerna, R.J.: Compensated compactness and general systems of conservation laws. *Trans. Amer. Math. Soc.* **292**, 383–420 (1985)
14. do Carmo, M.P.: *Riemannian Geometry*. Transl. by F. Flaherty, Boston, MA: Birkhäuser, 1992
15. Dong, G.-C.: The semi-global isometric imbedding in R^3 of two-dimensional Riemannian manifolds with Gaussian curvature changing sign cleanly. *J. Part. Diff. Eqs.* **6**, 62–79 (1993)
16. Efimov, N.V.: The impossibility in Euclidean 3-space of a complete regular surface with a negative upper bound of the Gaussian curvature. *Dokl. Akad. Nauk SSSR (N.S.)*, **150**, 1206–1209 (1963); *Sov. Math. Dokl.* **4**, 843–846 (1963)
17. Efimov, N.V.: Surfaces with slowly varying negative curvature. *Russ. Math. Surv.* **21**, 1–55 (1966)
18. Evans, L.C.: *Weak Convergence Methods for Nonlinear Partial Differential Equations*. CBMS-RCSM, **74**, Providence, RI: Amer. Math. Soc., 1990
19. Evans, L.C.: *Partial Differential Equations*. Providence, RI: Amer. Math. Soc., 1998
20. Gromov, M.: *Partial Differential Relations*. Berlin: Springer-Verlag, 1986
21. Han, Q., Hong, J.-X.: *Isometric embedding of Riemannian manifolds in Euclidean spaces*. Providence, RI: Amer. Math. Soc., 2006
22. Hilbert, D.: Ueber flächen von constanter Gausscher Krümmung. *Trans. Amer. Math. Soc.* **2**, 87–99 (1901)
23. Hong, J.-X.: Realization in R^3 of complete Riemannian manifolds with negative curvature. *Commun. Anal. Geom.* **1**, 487–514 (1993)
24. Hong, J.-X.: Recent developments of realization of surfaces in \mathbb{R}^3 . *AMS/IP Stud. Adv. Math.* **20**, Providence, RI: Amer. Math. Soc., 2001
25. Lions, P.-L., Perthame, B., Souganidis, P.: Existence and stability of entropy solutions for the hyperbolic systems of isentropic gas dynamics in Eulerian and Lagrangian coordinates. *Comm. Pure Appl. Math.* **49**, 599–638 (1996)
26. Lions, P.-L., Perthame, B., Tadmor, E.: Kinetic formulation of the isentropic gas dynamics and p -systems. *Commun. Math. Phys.* **163**, 169–172 (1994)
27. Mardare, S.: The fundamental theorem of surface theory for surfaces with little regularity. *J. Elasticity* **73**, 251–290 (2003)
28. Mardare, S.: On Pfaff systems with L^p coefficients and their applications in differential geometry. *J. Math. Pure Appl.* **84**, 1659–1692 (2005)
29. Morawetz, C.S.: On a weak solution for a transonic flow problem. *Comm. Pure Appl. Math.* **38**, 797–818 (1985)
30. Morawetz, C.S.: On steady transonic flow by compensated compactness. *Methods Appl. Anal.* **2**, 257–268 (1995)
31. Morawetz, C.S.: Mixed equations and transonic flow. *J. Hyper. Diff. Eqs.* **1**, 1–26 (2004)
32. Murat, F.: Compacité par compensation. *Ann. Scuola Norm. Pisa* (4) **5**, 489–507 (1978)
33. Nash, J.: The imbedding problem for Riemannian manifolds. *Ann. Math.* (2) **63**, 20–63 (1956)
34. Poznyak, È. G., Shikin, E.V.: Small parameters in the theory of isometric imbeddings of two-dimensional Riemannian manifolds in Euclidean spaces. In: *Some Questions of Differential Geometry in the Large*, Amer. Math. Soc. Transl. Ser. 2, **176**, Providence, RI: Amer. Math. Soc., 1996, pp. 151–192
35. Protter, M.H., Weinberger, H.F.L.: *Maximum Principles in Differential Equations*. Berlin-Heidelberg-New York: Springer, 1984

36. Rozendorn, È. R.: Surfaces of negative curvature. In: *Geometry*, III, Encyclopaedia Math. Sci. **48**, Berlin: Springer, 1992, pp. 87–178, 251–256
37. Serre, D.: *Systems of Conservation Laws*. Vols. **1–2**, Cambridge: Cambridge University Press, 1999, 2000
38. Tartar, L.: Compensated compactness and applications to partial differential equations. In: *Nonlinear Analysis and Mechanics*. Heriot-Watt Symposium IV, Res. Notes in Math. **39**, Boston-London: Pitman, 1979, pp. 136–212
39. Vaziri, A., Mahedevan, L.: Localized and extended deformations of elastic shells. Proc. National Acad. Sci. USA **105**(23), 7913–7918 (2008)
40. Yau, S.-T.: Review of geometry and analysis. In: *Mathematics: Frontiers and Perspectives*. International Mathematics Union, Eds. V. Arnold, M. Atiyah, P. Lax, B. Mazur, Providence, RI: Amer. Math. Soc., 2000, pp. 353–401

Communicated by P. Constantin